

E116 Handout on Section 1.1-1.8

1. a) Give some examples of scalar quantities
b) Give some examples of vector quantities
- 2) It is often quoted that 1 kg (SI units) is equivalent to 2.2 lb (US Customary units). Is this statement correct? Why or why not?
- 3) a) List 2 effects that cause the acceleration due to gravity, g , to vary on earth from a constant value.
b) What is the value of g in SI units that the book will use for solving all problems?
c) What is the value of g in US Customary units that the book will use for solving all problems?
- 4) By what factor would the weight of an object be reduced if it were in an orbit at a distance above the earth equal to the earth's radius?
- 5) Add the following two vectors graphically (approximately):

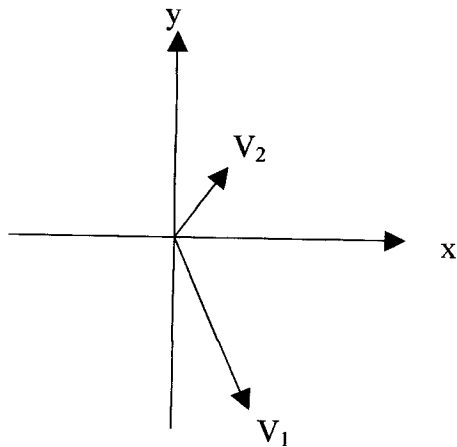

E116 Handout on Section 2.2, 1 of 3

A retarding force acts on a particle moving initially with a velocity of 100 m/s and gives it a deceleration as recorded by the oscilloscope record shown. Approximate the velocity of the particle at $t = 4$ s and at $t = 8$ s.

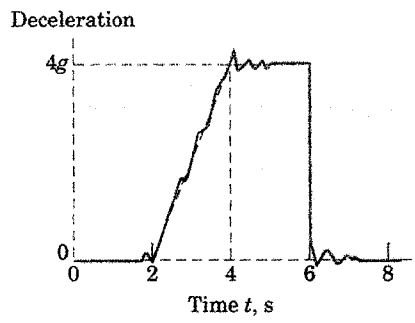

E116 Handout on Section 2.2, 2 of 3. (Use 5-step solution method)

Only do the first part (determine the acceleration a) – if you want, you can try outside of class to show that the particle never reaches the 30-m displacement.

If the velocity v of a particle moving along a straight line decreases linearly with its displacement s from 20 m/s to a value approaching zero at $s = 30$ m, determine the acceleration a of the particle when $s = 15$ m and show that the particle never reaches the 30-m displacement.

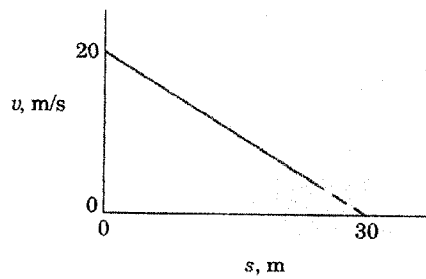

E116 Handout on Section 2.2, 3 of 3. (Use 5-step solution method)

A test projectile is fired horizontally into a viscous liquid with a velocity v_0 . The retarding force is proportional to the square of the velocity, so that the acceleration becomes $a = -kv^2$. Derive expressions for the distance D traveled in the liquid and the corresponding time t required to reduce the velocity to $v_0/2$. Neglect any vertical motion.

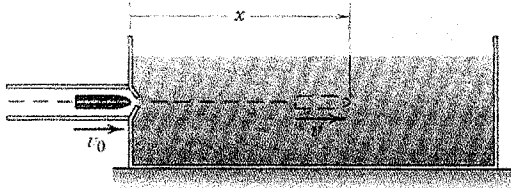

E116 Handout on Section 2.4, S07 (Use 5-step solution method)

A roofer tosses a small tool toward a coworker on the ground. What is the minimum horizontal velocity v_0 necessary so that the tool clears point B ? Locate the point of impact by specifying the distance s shown in the figure.

Ans. $v_0 = 6.64 \text{ m/s}$, $s = 2.49 \text{ m}$

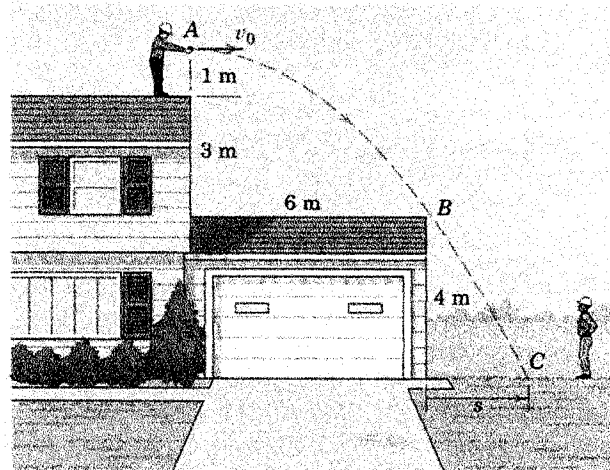

E116 Handout on Section 2.4 (Use 5-step solution method)

If the barrel of the rifle shown is aimed at point A , compute the distance δ below A to the point B where the bullet strikes. The muzzle velocity is 600 m/s .

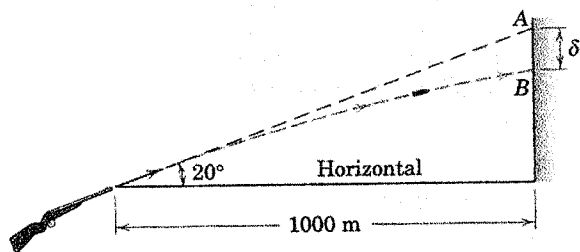

E116 Handout on Section 2.4 (Use 5-step solution method)

A projectile is launched from point A with the initial conditions shown in the figure. Determine the slant distance s which locates the point B of impact. Calculate the time of flight t .

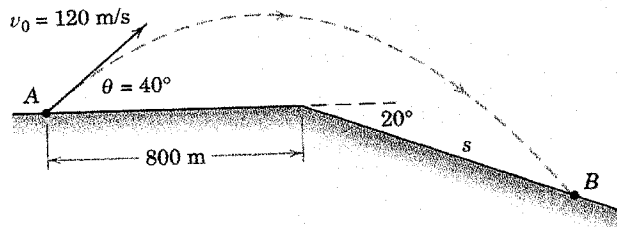

PROBLEMS

Introductory Problems

A particle moves in a circular path of 0.4-m radius. Calculate the magnitude a of the acceleration of the particle (a) if its speed is constant at 0.6 m/s and (b) if its speed is 0.6 m/s but is increasing at the rate of 1.2 m/s each second.

Ans. (a) $a = 0.9 \text{ m/s}^2$, (b) $a = 1.5 \text{ m/s}^2$

Six acceleration vectors are shown for the car whose velocity vector is directed forward. For each acceleration vector describe in words the instantaneous motion of the car.

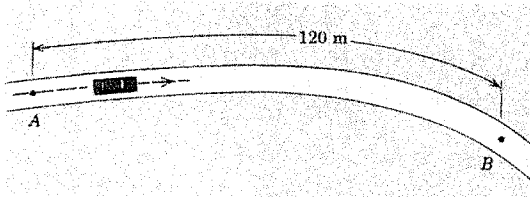
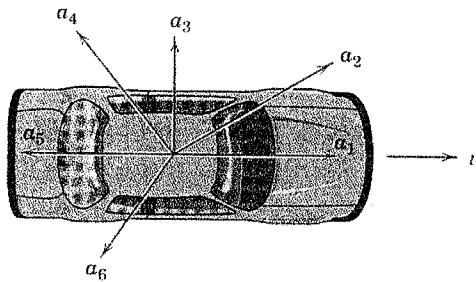

A car travels along the level curved road with a speed that is decreasing at the constant rate of 0.6 m/s each second. The speed of the car as it passes point A is 16 m/s. Calculate the magnitude of the total acceleration of the car as it passes point B which is 120 m along the road from A. The radius of curvature of the road at B is 60 m.

Ans. $a = 1.961 \text{ m/s}^2$

E116 Handout on Section 2.5, after trying the GP

A baseball player releases a ball with the initial conditions shown in the figure. Determine the radius of curvature of the trajectory (a) just after release and (b) at the apex. For each case, compute the time rate of change of the speed.

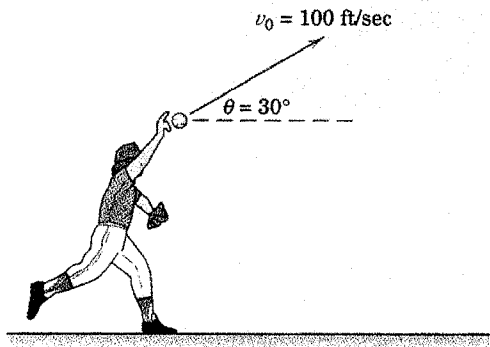

a)
 $\rho =$ _____

$\dot{v} =$ _____

b)
 $\rho =$ _____

$\dot{v} =$ _____

c)
 $\rho =$ _____

$\dot{v} =$ _____

(c) Also, determine the radius of curvature ρ and the time rate of change of speed \dot{v} 1 second after release.

ENGR 116 Handout on Related Rates, before doing Section 2.6, Meriam

- 1) If $y = x^2$, and, at a given instant in time, $x = 10 \text{ ft}$ and $\frac{dx}{dt} = 18 \text{ ft/sec}$, find $\frac{dy}{dt}$.
- 2) If the rocket path is 10,000 ft away (horizontal distance) and $v = 1,000 \text{ ft/sec}$ (constant), find $\dot{\theta}$ and \dot{r} for
 - a) $\theta = 0^\circ$
 - b) $\theta = 30^\circ$
 - c) $\theta = 45^\circ$
 - d) $\theta = 60^\circ$
 - e) for which angle is $\dot{\theta}$ the largest? The smallest?
 - f) for which angle is \dot{r} the largest? The smallest?
 - g) what would you expect $\dot{\theta}$ and \dot{r} to approach as $\theta \rightarrow 90^\circ$?

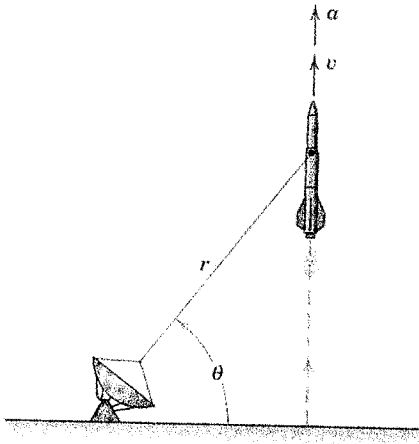

- 3) If a man is 6 feet tall, find the rate of change of the length of his shadow, in units of ft/hour, at:
 - a) 12:00 noon
 - b) 3:00 PM(Note: make the simplifying assumption of a 12-hour day, with the sun directly overhead at 12:00 noon)

ENGR 116 Handout on Section 2.6, Meriam 1 of 3

Rectangular Relationships:

$$\vec{v} = v_x \hat{u}_x + v_y \hat{u}_y = \dot{x} \hat{u}_x + \dot{y} \hat{u}_y$$

$$\vec{a} = a_x \hat{u}_x + a_y \hat{u}_y = \ddot{x} \hat{u}_x + \ddot{y} \hat{u}_y$$

Polar Relationships:

$$\vec{v} = v_r \hat{u}_r + v_\theta \hat{u}_\theta = \dot{r} \hat{u}_r + r \dot{\theta} \hat{u}_\theta$$

$$\vec{a} = a_r \hat{u}_r + a_\theta \hat{u}_\theta = (\ddot{r} - r \dot{\theta}^2) \hat{u}_r + (r \ddot{\theta} + 2 \dot{r} \dot{\theta}) \hat{u}_\theta$$

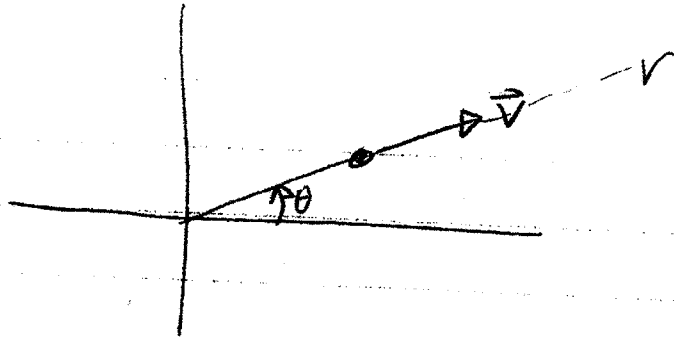

$$v_r =$$

$$v_\theta =$$

$$\dot{r} =$$

$$\dot{\theta} =$$

$$v_x =$$

$$v_y =$$

$$\dot{x} =$$

$$\dot{y} =$$

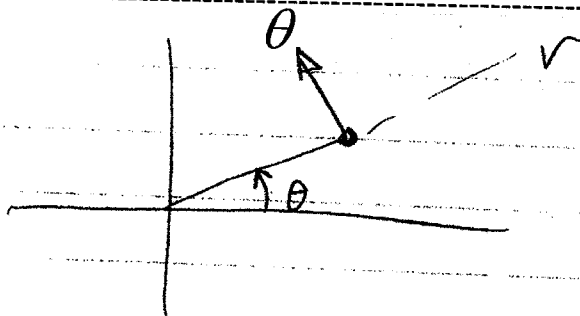

$$v_r =$$

$$v_\theta =$$

$$\dot{r} =$$

$$\dot{\theta} =$$

$$v_x =$$

$$v_y =$$

$$\dot{x} =$$

$$\dot{y} =$$

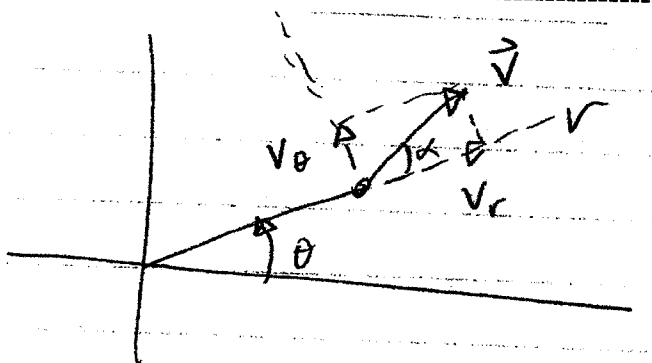

$$v_r =$$

$$v_\theta =$$

$$\dot{r} =$$

$$\dot{\theta} =$$

$$v_x =$$

$$v_y =$$

$$\dot{x} =$$

$$\dot{y} =$$

ENGR 116 Handout on Section 2.6, Meriam 2 of 3 (Use 5-step problem solving method)

The rocket is fired vertically and tracked by the radar station shown. When θ reaches 50° , other corresponding measurements give the values $r = 20,000$ ft, $\ddot{r} = 70\text{ft}/\text{sec}^2$, and $\dot{\theta} = 0.02\text{rad}/\text{sec}$. Calculate the magnitudes of the velocity and acceleration of the rocket at this position.

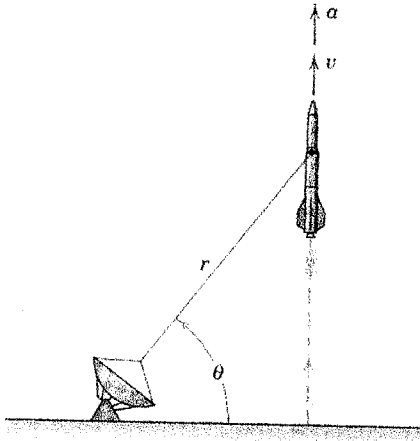

ENGR 116 Handout on Section 2.6, Meriam 3 of 3

A model airplane flies over an observer O in a straight line at constant speed. Determine the signs (+, -, or 0) of the following quantities at each position A, B and C:

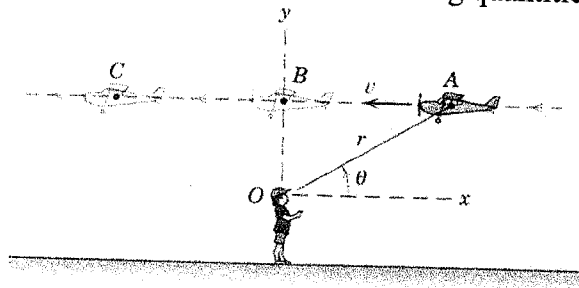

Position	Sign of $\dot{\theta}$	Sign of \dot{r}	Sign of $\ddot{\theta}$	Sign of \ddot{r}
A				
B				
C				

Note: for the last 2 columns, use the Polar Relationships (the first 2 columns can be determined by inspection of the physical situation):

$$\vec{v} = v_r \hat{u}_r + v_\theta \hat{u}_\theta = \dot{r} \hat{u}_r + r \dot{\theta} \hat{u}_\theta$$

$$\vec{a} = a_r \hat{u}_r + a_\theta \hat{u}_\theta = (\ddot{r} - r\dot{\theta}^2) \hat{u}_r + (r\ddot{\theta} + 2\dot{r}\dot{\theta}) \hat{u}_\theta$$

Also, complete the following table (+, -, or 0):

Position	Sign of \dot{x}	Sign of \dot{y}	Sign of \ddot{x}	Sign of \ddot{y}
A				
B				
C				

Note: A coordinate system is just a tool for tracking the kinematics (motion) of a particle – the actual physical motion of the particle is the same regardless of the coordinate system used to track its motion.

E116 Handout on Section 2.7, 1 of 2

The particle P moves along the space curve and has a velocity $\mathbf{v} = 4\mathbf{i} - 2\mathbf{j} - \mathbf{k}$ m/s for the instant shown. At the same instant the particle has an acceleration \mathbf{a} whose magnitude is 8 m/s^2 . Calculate the radius of curvature ρ of the path for this position and the rate \dot{v} at which the magnitude of the velocity is increasing.

$$\rho = \underline{\hspace{4cm}}$$

$$\dot{v} = \underline{\hspace{4cm}}$$

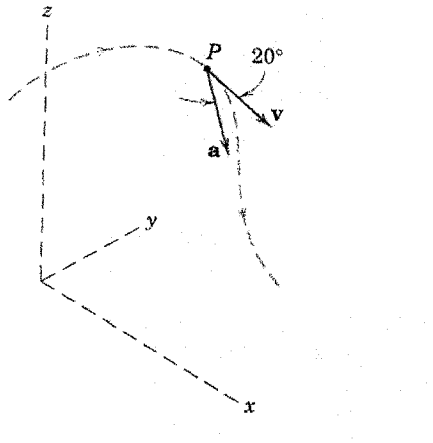

E116 Handout on Section 2.7, 2 of 2

The radar antenna at P tracks the jet aircraft A , which is flying horizontally at a speed u and an altitude h above the level of P . Determine the expressions for the components of the velocity in the spherical coordinates of the antenna motion.

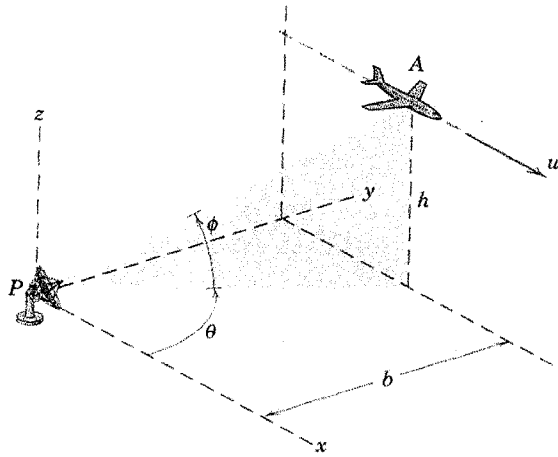

$$v_R = \underline{\hspace{10em}}$$

$$v_\theta = \underline{\hspace{10em}}$$

$$v_\phi = \underline{\hspace{10em}}$$

2/170

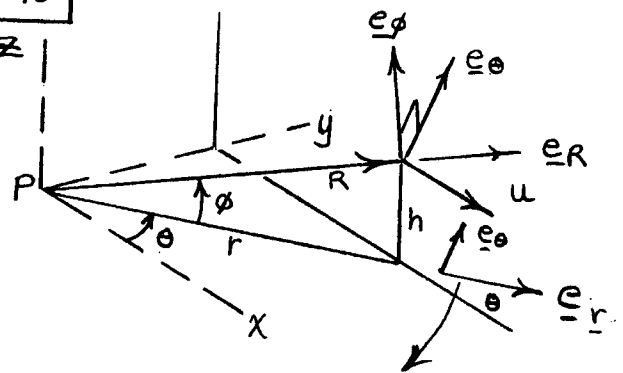

Resolve u along \underline{e}_θ & \underline{e}_r directions:

$$\underline{e}_\theta : -u \sin \theta = v_\theta$$

$$\underline{e}_r : u \cos \theta = v_r$$

Now resolve v_r along \underline{e}_R & \underline{e}_ϕ directions:

$$\underline{e}_R : v_r \cos \phi = \frac{u \cos \theta \cos \phi}{1} = v_R$$

$$\underline{e}_\phi : -v_r \sin \phi = \frac{-u \cos \theta \sin \phi}{1} = v_\phi$$

or, use dot products

$$\hat{u}_r = \cos \theta \hat{i} + \sin \theta \hat{j}$$

$$\hat{u}_\theta = -\sin \theta \hat{i} + \cos \theta \hat{j}$$

} all
quadrant.

$$\hat{u}_R = \cos \phi \hat{u}_{xy} + \sin \phi \hat{k}$$

$$= \cos \phi (\cos \theta \hat{i} + \sin \theta \hat{j}) + \sin \phi \hat{k}$$

$$\hat{u}_\phi = -\sin \phi \hat{u}_{xy} + \cos \phi \hat{k}$$

$$= -\sin \phi \cos \theta \hat{i} - \sin \phi \sin \theta \hat{j} + \cos \phi \hat{k}$$

ENGR 116 Handout on Section 2.8, Meriam

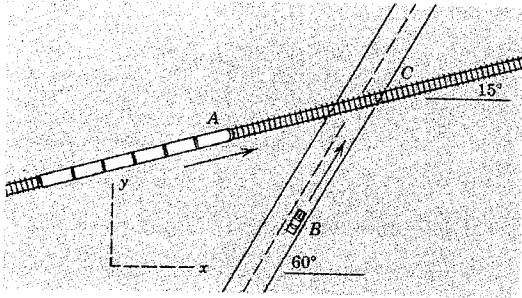

Train A travels with a constant speed $v_A = 120$ km/h along the straight and level track. The driver of car B, anticipating the railway grade crossing C, decreases the car speed of 90 km/h at the rate of 3 m/s^2 . Determine the velocity and acceleration of the train relative to the car.

Ans. $\mathbf{v}_{A/B} = 70.9\mathbf{i} - 46.9\mathbf{j} \text{ km/h}$

$\mathbf{a}_{A/B} = 1.5\mathbf{i} + 2.60\mathbf{j} \text{ m/s}^2$

Two aircraft, A and B, are flying horizontally in the same vertical plane at the respective altitudes of 2.40 km and 1.80 km and at the respective velocities of 800 km/h and 600 km/h. When the line-of-sight angle θ from B to A reaches 30° , determine the rate at which the distance $r_{A/B}$ from B to A is increasing and the rate at which θ is increasing.

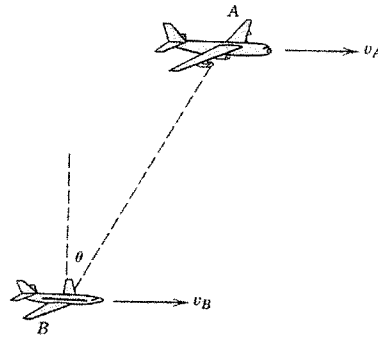

ENGR 116 Handout on Section 2.9, Meriam

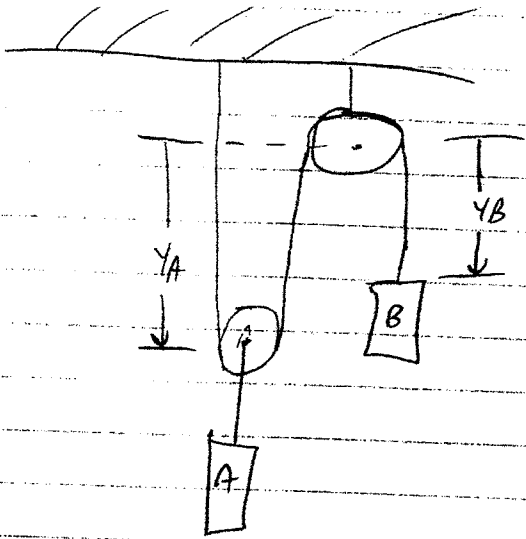

find v_A if $v_B = 1 \frac{m}{sec}$

downward

ENGR 116 Handout 1 of 2 on Section 3.4 Meriam (Use 5-step method to find solution)

Determine the tension P in the cable which will give the 100-lb block a steady acceleration of 5 ft/sec^2 up the incline. (answer: $P = 43.8 \text{ lb}$)

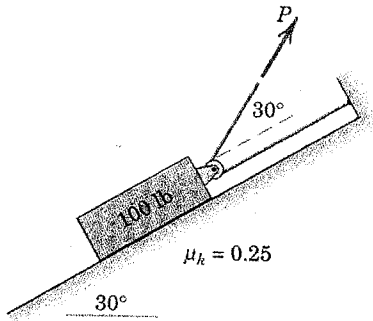

ENGR 116 Handout 2 of 2 on Section 3.4 Meriam (Use 5-step method to find solution)

The collar A is free to slide along the smooth shaft B mounted in the frame. The plane of the frame is vertical. Determine the horizontal acceleration a of the frame necessary to maintain the collar in a fixed position on the shaft.

Ans. $a = 5.66 \text{ m/s}^2$

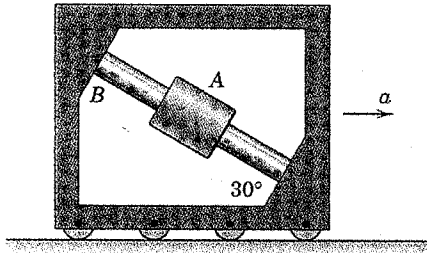

CONCEPTUAL *Physics* PRACTICE PAGE

Chapter 5 Newton's Third Law of Motion Action and Reaction Pairs

1. In the example below, the action-reaction pair is shown by the arrows (vectors), and the action-reaction described in words. In (a) through (g) draw the other arrow (vector) and state the reaction to the given action. Then make up your own example in (h).

Example:



Fist hits wall.

Wall hits fist.



Head bumps ball.

(a) _____

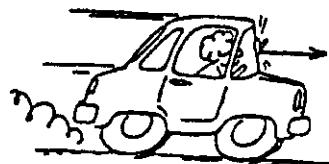

Windshield hits bug.

(b) _____

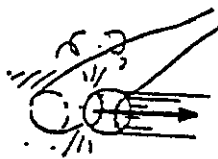

Bat hits ball.

(c) _____

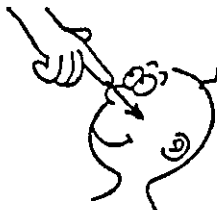

Hand touches nose.

(d) _____

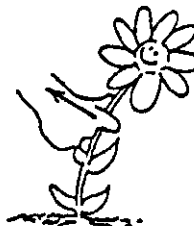

Hand pulls on flower.

(e) _____

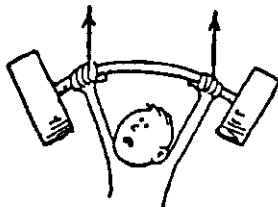

Athlete pushes bar upward.

(f) _____

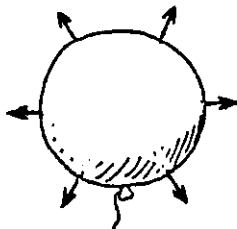

Compressed air pushes balloon surface outward.

(g) _____

(h) _____

2. Draw arrows to show the chain of at least six pairs of action-reaction forces below.

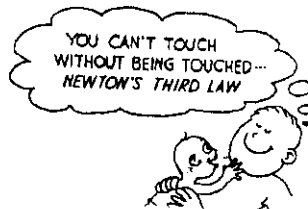
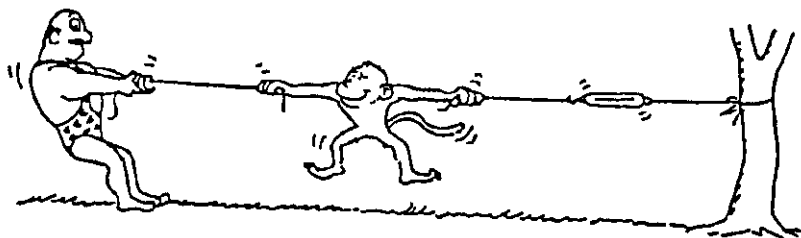

1)

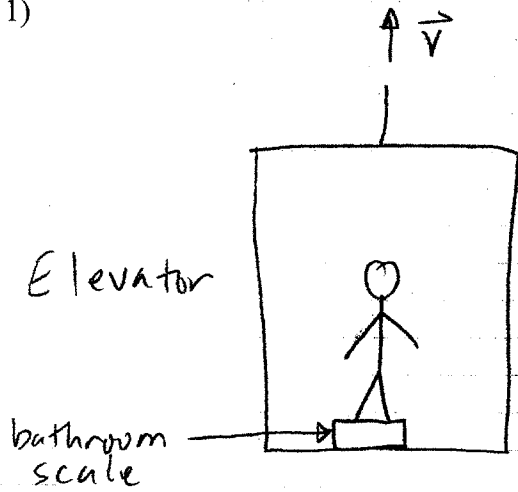

Describe the scale reading when:

a) $v = 0 \frac{\text{ft}}{\text{s}}$, elevator begins to move upward

b) $v = 1 \frac{\text{ft}}{\text{s}}$, constant

c) $v = 1 \frac{\text{ft}}{\text{s}}$, slowing down

man weighs 150 lb

2) What does a scale measure? _____

3) Calculate the scale reading when:

a) $v = \text{constant upward}$

b) $a = 2 \text{ ft/s}^2$ upward (speeding up)

c) $a = 2 \text{ ft/s}^2$ downward (slowing up)

ENGR 116 Handout 2 of 3 on Section 3.5 Meriam

3/51 If the 2-kg block passes over the top B of the circular portion of the path with a speed of 3.5 m/s, calculate the magnitude N_B of the normal force exerted by the path on the block. Determine the maximum speed v which the block can have at A without losing contact with the path.

Ans. $N_B = 9.41$ N, $v = 4.52$ m/s

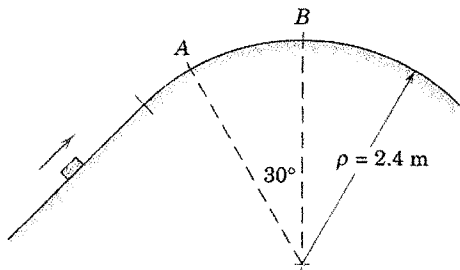

ENGR 116 Handout 3 of 3 on Section 3.5 Meriam (This is an assigned problem)

A pilot flies an airplane at a constant speed of 600 km/h in the in the vertical circle of radius 1000 m.

Calculate the normal force exerted by the bottom of the seat on the 90-kg pilot at point A and at point B.

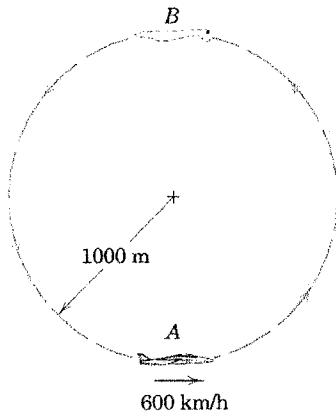

$$N_A = \underline{\hspace{2cm}}$$

$$N_B = \underline{\hspace{2cm}}$$

ENGR 116 Handout 1 of 3 on Section 3.6 and 3.7, Meriam

- General Definition: Work, $W = \int \vec{F} \cdot d\vec{r}$
- If the force is constant, and the displacement is in a straight line, then:

$$\text{Work, } W = \vec{F} \cdot \vec{\Delta r} = F \cdot \Delta r \cdot \cos \theta$$

- 1) In order to calculate the work done by the gravitational force (“weight”) on the 8-lb block, first answer the following:
 - a) Which direction does the force \vec{F} point?
 - b) Which direction does the displacement $\vec{\Delta r}$ point?
 - c) Is $\vec{F} \cdot \vec{\Delta r}$ positive or negative?
 - d) Calculate the work done by the gravitational force, $W = \vec{F} \cdot \vec{\Delta r}$

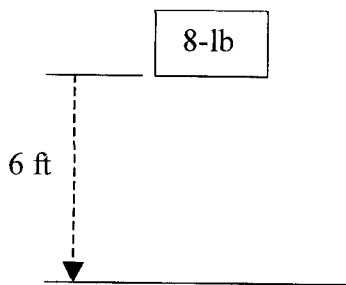

- 2) In order to calculate the work done by the gravitational force (“weight”) on the 8-lb block sliding down the frictionless incline, first answer the following:
 - a) Which direction does the force \vec{F} point? Write \vec{F} as a vector:
 - b) Which direction does the displacement $\vec{\Delta r}$ point? Write $\vec{\Delta r}$ as a vector:
 - c) Is $\vec{F} \cdot \vec{\Delta r}$ positive or negative?
 - d) What is the angle θ made between \vec{F} and $\vec{\Delta r}$ when they are placed tail-to-tail?
 - e) Calculate the work done by the gravitational force, $W = \vec{F} \cdot \vec{\Delta r}$
 - f) Is the answer the same as #1? Explain?

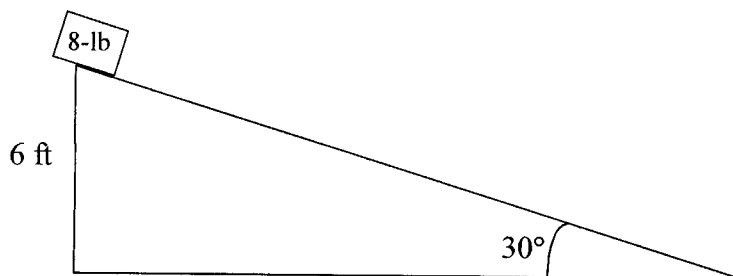

ENGR 116 Handout 2 of 3 on Section 3.6 and 3.7, Meriam

- Definition: $\sum W = \Delta KE$ (Net Work = Change in Kinetic Energy)

- 1) a) Calculate the work done by friction (this is the Net Work, since there are no other forces acting on the 20-kg block).
b) Find the average friction force, \vec{f}_{avg} .

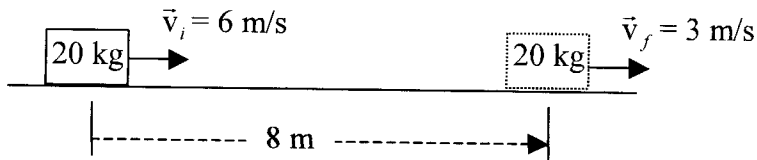

- 2) a) Calculate the Net Work done on the 20-kg block.
b) Calculate the work done by the earth's gravitational force ("weight") on the 20-kg block.
c) Calculate the work done by friction on the 20-kg block.
d) Find the average friction force, \vec{f}_{avg} .

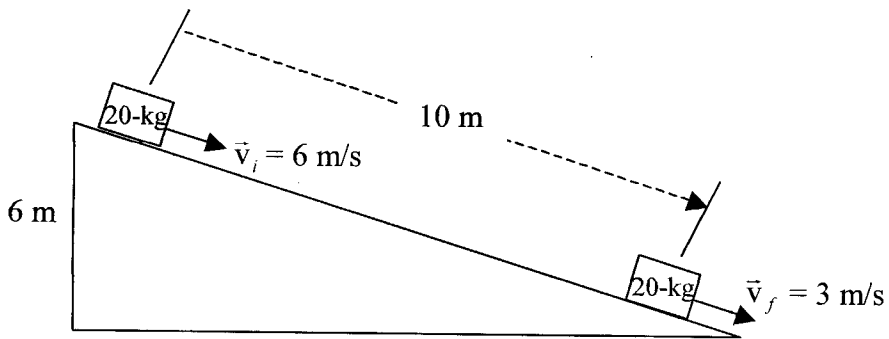

ENGR 116 Handout 3 of 3 on Section 3.6 and 3.7, Meriam

- Definition: $\sum W' = \Delta KE + \Delta PE_{\text{gravity}} + \Delta PE_{\text{spring}}$

$$\sum W' = \left(\frac{1}{2} m(v_f)^2 - \frac{1}{2} m(v_i)^2 \right) + mg\Delta h + \left(\frac{1}{2} k(x_f)^2 - \frac{1}{2} k(x_i)^2 \right)$$
- Note that $\Delta h = h_f - h_i$, which is most easily interpreted as the change in height of the object:
 - Δh is **positive** if the object ends up at a **higher height**;
 - Δh is **negative** if the object ends up at a **lower height**.
- Note that x_f and x_i are the final and initial amounts the spring is **displaced** (positive if stretched; negative if compressed) from its natural, un-stretched length, not the final and initial lengths of the spring.

- 1) The 15-lb cylindrical collar is released from rest in the position shown and drops onto the spring. Calculate the velocity v of the cylinder when the spring has been compressed 2 in.

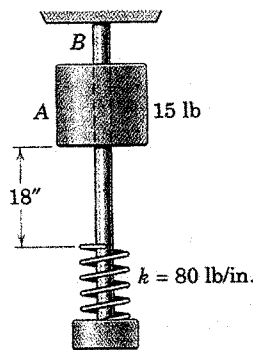

- 2) Note: This is a problem from the CourseWork. Why are the answers different for parts (a) and (b)?

Each of the two systems is released from rest. Calculate the velocity v of each 25-kg cylinder after the 20-kg cylinder has dropped 2 m. The 10-kg cylinder of case (a) is replaced by a $10(9.81)$ -N force in case (b).

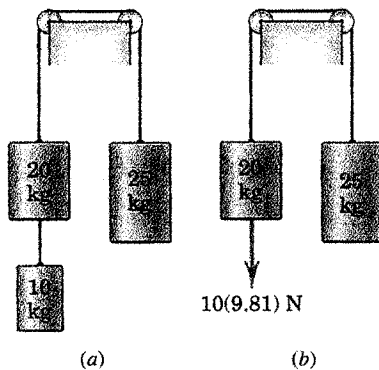

ENGR 116 Handout on Section 3.9, Meriam (Use Impulse-Momentum methods to solve)

3/195 The 20-lb block is moving to the right with a velocity of 2 ft/sec on a horizontal surface when a force P is applied to it at time $t = 0$. Calculate the velocity v of the block when $t = 0.4$ sec. The coefficient of kinetic friction is $\mu_k = 0.3$.

Ans. $v = 5.86$ ft/sec

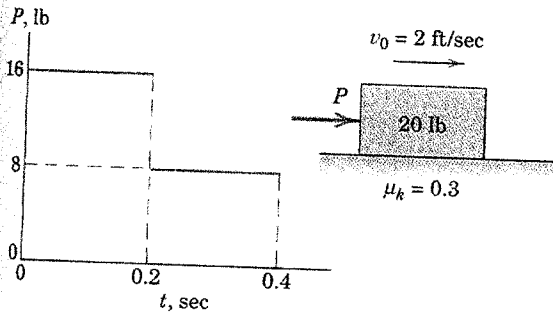

Problem 3/195

3/187 A 75-g projectile traveling at 600 m/s strikes and becomes embedded in the 50-kg block, which is initially stationary. Compute the energy lost during the impact. Express your answer as an absolute value $|\Delta E|$ and as a percentage n of the original system energy E .

Ans. $|\Delta E| = 13\,480$ J, $n = 99.9\%$

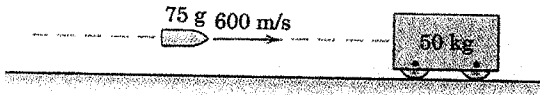

Problem 3/187

ENGR 116 Handout on Section 3.10, Meriam

At a certain instant, the particle of mass m has the position and velocity shown in the figure, and it is acted upon by the force F . Determine its angular momentum about point O and the time rate of change of this angular momentum.

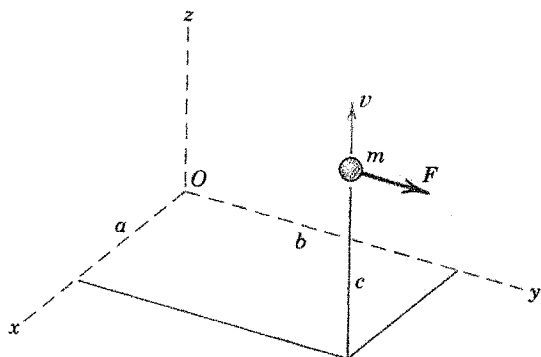

The small spheres, which have the masses and initial velocities shown in the figure, strike and become attached to the spiked ends of the rod, which is freely pivoted at O and is initially at rest. Determine the angular velocity ω of the assembly after impact. Neglect the mass of the rod.

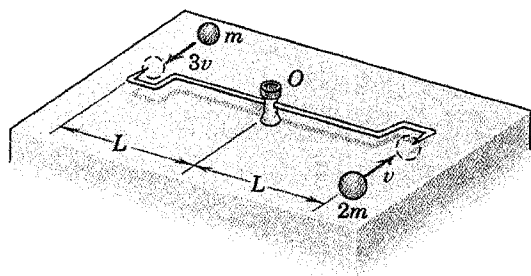

ENGR 116 Handout on Section 3.12, Meriam

Tennis balls are usually rejected if they fail to rebound to waist level when dropped from shoulder level. If a ball just passes the test as indicated in the figure, determine the coefficient of restitution e and the percentage n of the original energy lost during the impact.

Ans. $e = 0.829$, $n = 31.2\%$

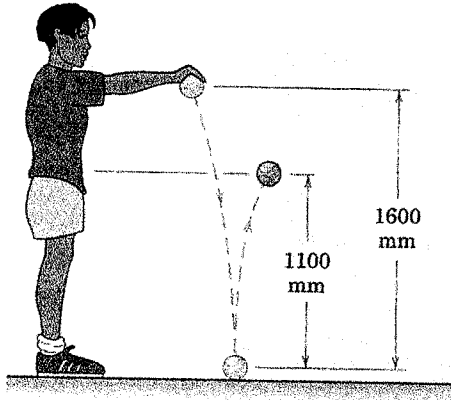

Compute the final velocities v_1' and v_2' after collision of the two cylinders which slide on the smooth horizontal shaft. The coefficient of restitution is $e = 0.6$.

Ans. $v_1' = 4.52$ m/s to the left
 $v_2' = 2.68$ m/s to the right

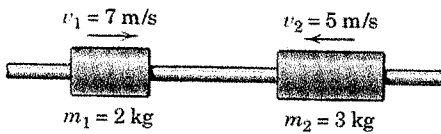

ENGR 116 Handout on Section 4.2, Meriam

The three monkeys *A*, *B*, and *C* with masses of 10, 12, and 8 kg, respectively, are climbing up and down the rope suspended from *D*. At the instant represented, *A* is descending the rope with an acceleration of 1.6 m/s^2 , and *C* is pulling himself up with an acceleration of 0.9 m/s^2 . Monkey *B* is climbing up with a constant speed of 0.6 m/s . Treat the rope and the monkeys as a complete system and calculate the tension T in the rope at *D*.

Ans. $T=286 \text{ N}$

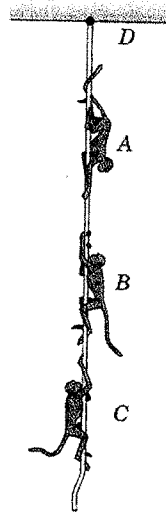

ENGR 116 Handout on Sections 4.3-4.5, Meriam

The woman *A*, the captain *B*, and the sailor *C* weigh 120, 180, and 160 lb, respectively, and are sitting in the 300-lb skiff which is gliding through the water with a speed of 1 knot. If the three people change their positions as shown in the second figure, find the distance *x* from the skiff to the position where it would have been if the people had not moved. Neglect any resistance to motion afforded by the water. Does the sequence or timing of the change in positions affect the final result?

Ans. $x = 0.316$ ft, No

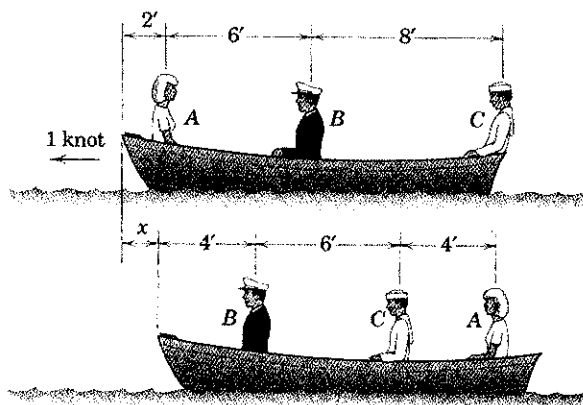

The two small spheres, each of mass *m*, are rigidly connected by a rod of negligible mass. The center *C* of the rod has a velocity *v* in the *x*-direction, and the rod is rotating counterclockwise at the constant rate $\dot{\theta}$. For a given value of θ , write the expressions for (a) the linear momentum of each sphere and (b) the linear momentum **G** of the system of the two spheres.

Ans. (a) $G_1 = m[(v + b\dot{\theta} \sin \theta)\mathbf{i} - (b\dot{\theta} \cos \theta)\mathbf{j}]$
 $G_2 = m[(v - b\dot{\theta} \sin \theta)\mathbf{i} + (b\dot{\theta} \cos \theta)\mathbf{j}]$
 (b) $\mathbf{G} = 2mv\mathbf{i}$

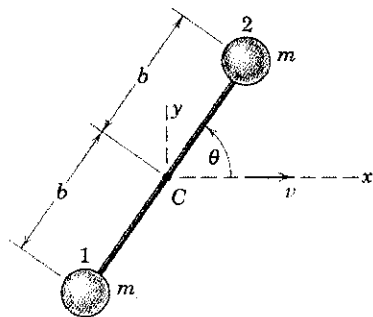

Also, calculate the relative angular momentum about the center of gravity point, $G = C$. Is this the same as the absolute angular momentum about the center of gravity? If yes, show that they are equal by also calculating the absolute angular momentum about the center of gravity.

ENGR 116 Handout on Section 5.2, 1 of 2, Meriam

5/4 The small cart is released from rest in position 1 and requires 0.638 seconds to reach position 2 at the bottom of the path, where its center G has a velocity of 14.20 ft/sec. Determine the angular velocity ω of line AB in position 2 and the average angular velocity ω_{av} of AB during the interval.

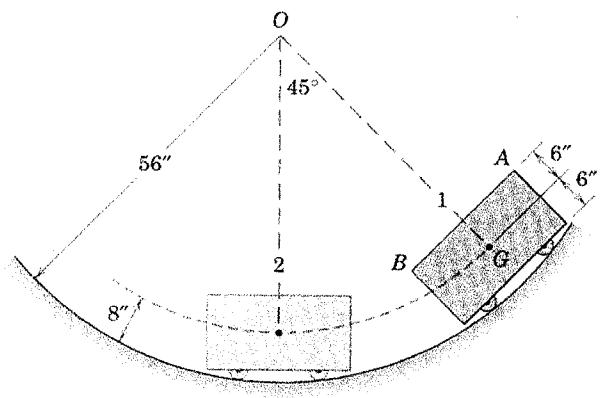

ENGR 116 Handout on Section 5.2, 2 of 2, Meriam
 Re-Work Sample Problem 5/3 (below) using the vector-geometric method (not cross products)

Sample Problem 5/3

The right-angle bar rotates clockwise with an angular velocity which is decreasing at the rate of 4 rad/s^2 . Write the vector expressions for the velocity and acceleration of point A when $\omega = 2 \text{ rad/s}$.

Solution. Using the right-hand rule gives

$$\omega = -2\mathbf{k} \text{ rad/s} \quad \text{and} \quad \alpha = +4\mathbf{k} \text{ rad/s}^2$$

The velocity and acceleration of A become

$$[\mathbf{v} = \omega \times \mathbf{r}] \quad \mathbf{v} = -2\mathbf{k} \times (0.4\mathbf{i} + 0.3\mathbf{j}) = 0.6\mathbf{i} - 0.8\mathbf{j} \text{ m/s} \quad \text{Ans.}$$

$$[\mathbf{a}_n = \omega \times (\omega \times \mathbf{r})] \quad \mathbf{a}_n = -2\mathbf{k} \times (0.6\mathbf{i} - 0.8\mathbf{j}) = -1.6\mathbf{i} - 1.2\mathbf{j} \text{ m/s}^2$$

$$[\mathbf{a}_t = \alpha \times \mathbf{r}] \quad \mathbf{a}_t = 4\mathbf{k} \times (0.4\mathbf{i} + 0.3\mathbf{j}) = -1.2\mathbf{i} + 1.6\mathbf{j} \text{ m/s}^2$$

$$[\mathbf{a} = \mathbf{a}_n + \mathbf{a}_t] \quad \mathbf{a} = -2.8\mathbf{i} + 0.4\mathbf{j} \text{ m/s}^2 \quad \text{Ans.}$$

The magnitudes of \mathbf{v} and \mathbf{a} are

$$v = \sqrt{0.6^2 + 0.8^2} = 1 \text{ m/s} \quad \text{and} \quad a = \sqrt{2.8^2 + 0.4^2} = 2.83 \text{ m/s}^2$$

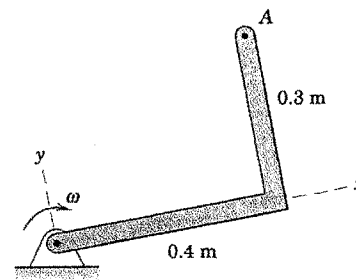

ENGR 116 Handout on Section 5.3, Meriam

5/39 Rotation of the lever OA is controlled by the motion of the contacting circular disk whose center is given a horizontal velocity v . Determine the expression for the angular velocity ω of the lever OA in terms of x .

$$\text{Ans. } \omega = \frac{v}{x\sqrt{(x/r)^2 - 1}}$$

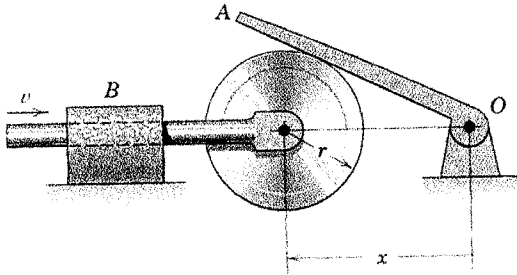

5/35 The telephone-cable reel rolls without slipping on the horizontal surface. If point A on the cable has a velocity $v_A = 0.8$ m/s to the right, compute the velocity of the center O and the angular velocity ω of the reel. (Be careful not to make the mistake of assuming that the reel rolls to the left.)

$$\text{Ans. } v_O = 1.2 \text{ m/s, } \omega = 1.333 \text{ rad/s CW}$$

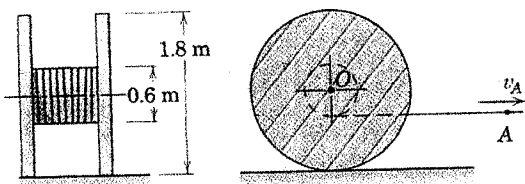

ENGR 116 Handout on Section 5.4, Meriam

The right-angle link has a counterclockwise angular velocity of 3 rad/s at the instant represented, and point B has a velocity $\mathbf{v}_B = 2\mathbf{i} - 0.3\mathbf{j}$ m/s. Determine the velocity of A using vector notation. Sketch the vector polygon which corresponds to the terms in the relative-velocity equation and estimate or measure the magnitude of \mathbf{v}_A .

Ans. $\mathbf{v}_A = 0.5\mathbf{i} + 0.9\mathbf{j}$ m/s

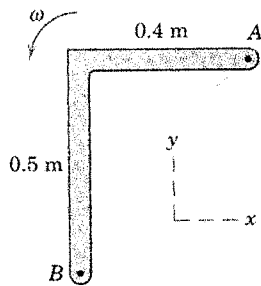

ENGR 116 Handout on Section 5.5, Meriam

5/101 The mechanism of Prob. 5/27 is repeated here. At the instant when $x_A = 0.85L$, the velocity of the slider at A is $v = 2$ m/s to the right. Determine the corresponding velocity of slider B and the angular velocity ω of bar AB if $L = 0.8$ m.

Ans. $v_B = 0.884$ m/s, $\omega = 3.20$ rad/s

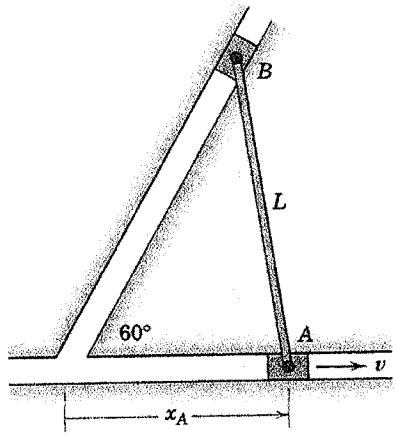

ENGR 116 Handout on Section 5.6, Meriam

5/119 For the instant represented, corner C of the rectangular plate has an acceleration of 5 m/s^2 in the negative y -direction, and the plate has a clockwise angular velocity of 4 rad/s which is decreasing by 12 rad/s each second. Determine the acceleration of A at this instant. Solve by scalar-geometric and by vector-algebraic methods. *Ans.* $a_A = 11.18 \text{ m/s}^2$

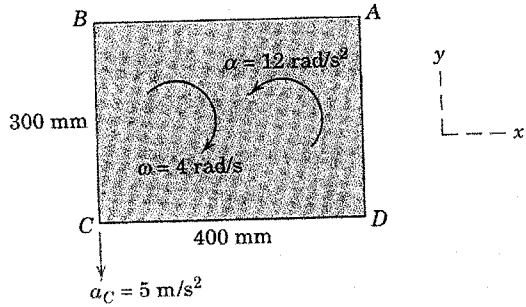

5/124 The center O of the disk has the velocity and acceleration shown in the figure. If the disk rolls without slipping on the horizontal surface, determine the velocity of A and the acceleration of B for the instant represented.

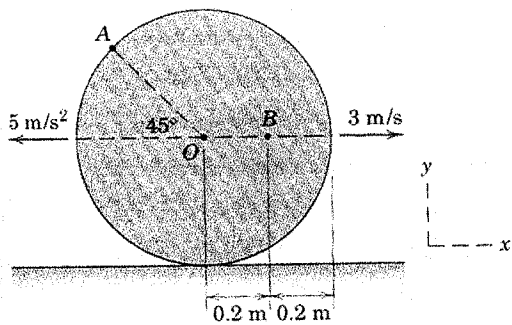

Problem 5/124

ENGR 116 Handout on Section B.1, Meriam

B/2 The two small spheres of mass m each are connected by the light rigid rod which lies in the x - z plane. Determine the mass moments of inertia of the assembly about the x -, y -, and z -axes.

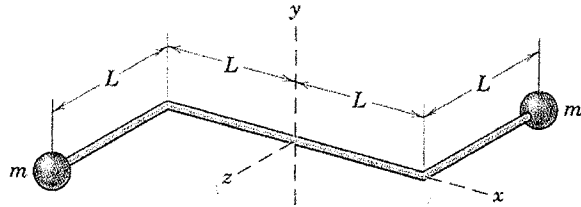

Determine the mass moments of inertia of the thin parabolic plate of mass m about the x -, y -, and z -axes.

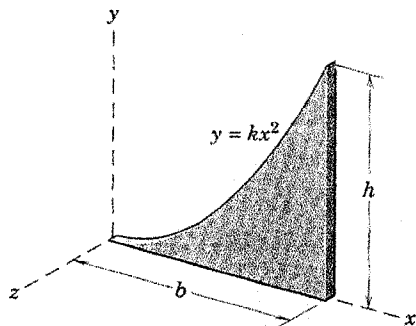

ENGR 116 Handout on Section 6.3, Meriam

6/11 The 1650-kg car has its mass center at G . Calculate the normal forces N_A and N_B between the road and the front and rear pairs of wheels under conditions of maximum acceleration. The mass of the wheels is small compared with the total mass of the car. The coefficient of static friction between the road and the rear driving wheels is 0.8.

Ans. $N_A = 6.85 \text{ kN}$, $N_B = 9.34 \text{ kN}$

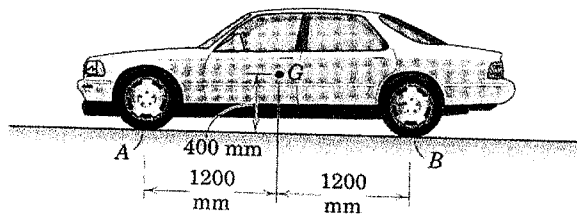

The uniform 60-lb log is supported by the two cables and used as a battering ram. If the log is released from rest in the position shown, calculate the initial tension induced in each cable immediately after release and the corresponding angular acceleration α of the cables.

Ans. $T_A = 12.99 \text{ lb}$, $T_B = 39.0 \text{ lb}$
 $\alpha = 8.05 \text{ rad/sec}^2$

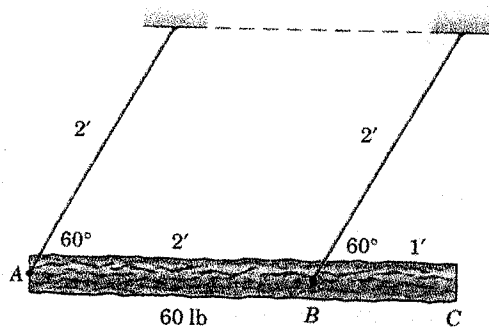

ENGR 116 Handout on Section 6.4, Meriam

6/33 The uniform 20-kg slender bar is pivoted at O and swings freely in the vertical plane. If the bar is released from rest in the horizontal position, calculate the initial value of the force R exerted by the bearing on the bar an instant after release.

Ans. $R = 49.0$ N

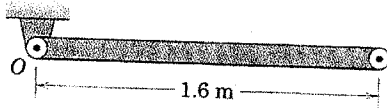

Problem 6/33

The uniform slender bar AB has a mass of 8 kg and swings in a vertical plane about the pivot at A . If $\dot{\theta} = 2$ rad/s when $\theta = 30^\circ$, compute the force supported by the pin at A at that instant.

Ans. $A = 56.3$ N

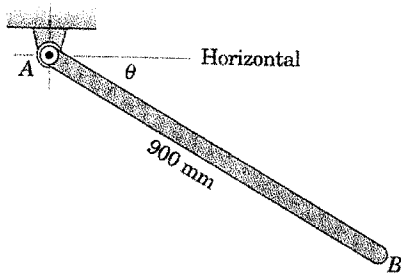

ENGR 116 Handout on Section 6.5, 1 of 2, Meriam

The uniform slender rod of mass m and length ℓ is lying motionless on the frictionless horizontal surface when a force \vec{P} is applied at various points as shown. Determine \vec{a}_G , α , \vec{a}_A and \vec{a}_B when

\vec{P} is applied at point:

- a) G
- b) B

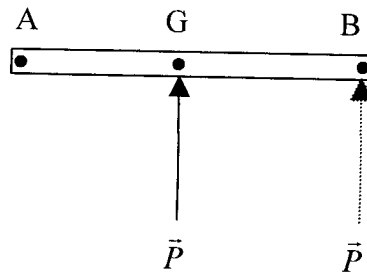

ENGR 116 Handout on Section 6.5, 2 of 2, Meriam

The 50-lb wheel has a centroidal radius of gyration of 5 in. If friction is sufficient to prevent slipping, compute the friction force F acting on the wheel during its downhill roll. What is the minimum coefficient of static friction μ_s to prevent slipping?

Ans. $F = 5.40$ lb, $\mu_s = 0.117$

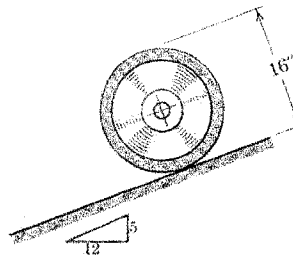

ENGR 116 Handout on Section 6.6, Meriam

6/115 The 32.2-lb wheel is released from rest and rolls on its hubs without slipping. Calculate the velocity v of the center O of the wheel after it has moved a distance $x = 10$ ft down the incline. The radius of gyration of the wheel about O is 5 in.

Ans. $v = 2.97$ ft/sec

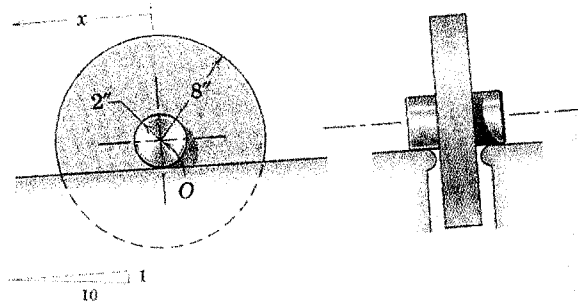

The velocity of the 8-kg cylinder is 0.3 m/s at a certain instant. What is its speed v after dropping an additional 1.5 m? The mass of the grooved drum is 12 kg, its centroidal radius of gyration is $\bar{k} = 210$ mm, and the radius of its groove is $r_i = 200$ mm. The frictional moment at O is a constant $3 \text{ N}\cdot\text{m}$.

Ans. $v = 3.01$ m/s

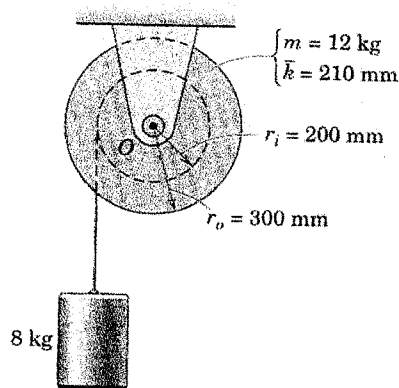

ENGR 116 Handout on Section 6.8, Meriam

The 2-oz bullet has a horizontal velocity of 1500 ft/sec as it strikes the 20-lb slender bar OA , which is suspended from point O and is initially at rest. Calculate the angular velocity ω which the bar with its embedded bullet has acquired immediately after impact.

Ans. $\omega = 5.60$ rad/sec

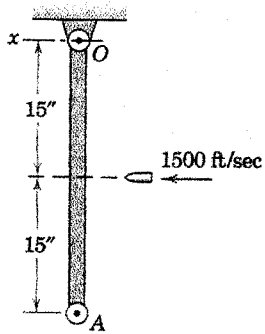

GP

A uniform slender bar of mass M and length L is translating on the smooth horizontal x - y plane with a velocity v_M when a particle of mass m traveling with a velocity v_m as shown strikes and becomes embedded in the bar. Determine the final linear and angular velocities of the bar with its embedded particle.

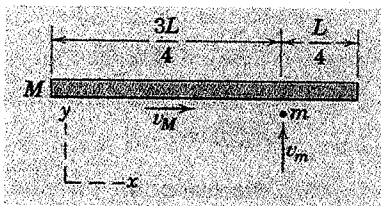

ENGR 116 Handout on Section 8.2, Meriam

Determine the natural frequency of the spring-mass system in both radians per second and cycles per second (Hz).

Ans. $\omega_n = 18$ rad/sec, $f_n = 2.86$ Hz

