

DUE DATE _____

NAME _____

ENGR/DRAFT 105 Assignment #5, Isometric Pictorials
(Note: Use isometric paper and draw mechanically for this assignment)

- 1) Do exercise 1-3 (not in textbook) – **HOWEVER, DO NOT DRAW THE OBJECTS!!!**
JUST DRAW THE ISOMETRIC BOX, ALL 6 SIDES, AND HAVE EACH BOX CHECKED BY THE INSTRUCTOR BEFORE DRAWING THE OBJECTS!!!
DO NOT DRAW ANY PROJECTION LINES FROM THE OBJECT – INSTEAD, USE DIVIDERS TO TRANSFER THE WIDTH, HEIGHT AND DEPTH FROM THE OBJECTS TO DRAW THE ISOMETRIC BOX – YOU MUST USE YOUR T-SQUARE AND 30 DEGREE TRIANGLE TO DRAW THE ISOMETRIC BOX. YOU ARE STRONGLY ENCOURAGED TO USE ISOMETRIC PAPER UNDER THE DRAWING TO HELP YOU DRAW THE ISOMETRIC BOX (AND LATER ON, THE OBJECT).

AFTER THE INSTRUCTOR APPROVES EACH BOX (ONE AT A TIME), THEN PROCEED TO DRAW THE OBJECT.

- 2) Do exercise 1-5 (not in textbook)
- 3) Draw an isometric mechanical drawing of the L-shaped wooden object with the hole on plain 8.5"x11" paper (ignore imperfections in the object).
- 4) Draw an isometric mechanical drawing of the foam (surfboard material) object on plain 8.5" x 11" paper (ignore imperfections in the object). **NOTE:** You must orient the whole on the front plane of the object, and it will appear as an ellipse.

Extra Credit: Do exercise 1-4 (not in textbook)

- **Staple this sheet to the front of your drawings in the correct order.**
- **Write your name at the top of the page.**
- **Write your name on each drawing.**

EXERCISE 1-3

use isometric grid paper

Make freehand sketches of the isometric objects shown below by copying them in the space provided to the right. Do not use a straightedge. If your box or object does not look correct, you probably drew a line that was not parallel to one of the isometric axes. You may find it helpful to use the isometric grid in the Appendix (page 333) by placing it under this sheet. Remember, the isometric box that you first sketch as a guide must have the overall shape of the object to be drawn.

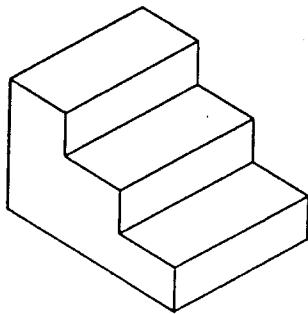
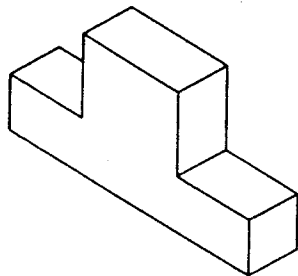
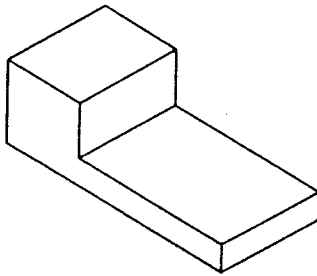

DRAWN BY

DATE

EXERCISE 1-5

use isometric grid paper

In the space provided on this page, make freehand sketches of the isometric objects shown below. Notice that all these objects contain some nonisometric lines. Remember to start with an isometric box. Do not use a straightedge. Part (c) was illustrated for you in Fig. 1-15.

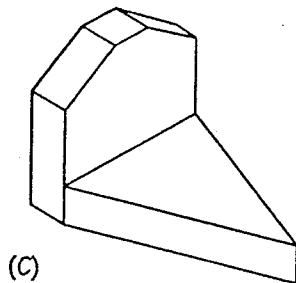
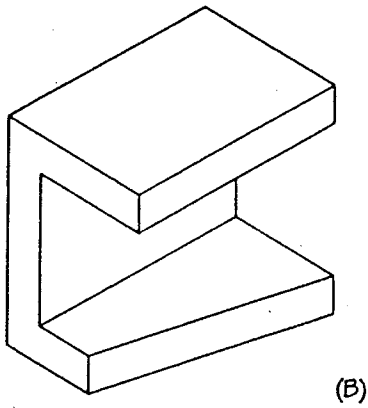
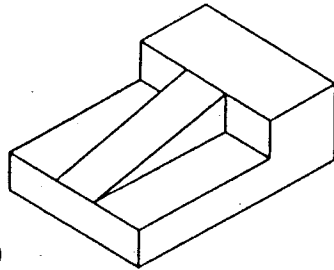

DRAWN BY _____

DATE _____

EXERCISE 1-4

Use isometric grid paper

In the space provided on this page, make freehand sketches by copying the isometric objects shown below. The first one was illustrated for you in Fig. 1-14. Do not use a straightedge. If your box or object does not look correct, you may have drawn a line that was not parallel to one of the isometric axes. Remember to start with an isometric box.

Extra Credit

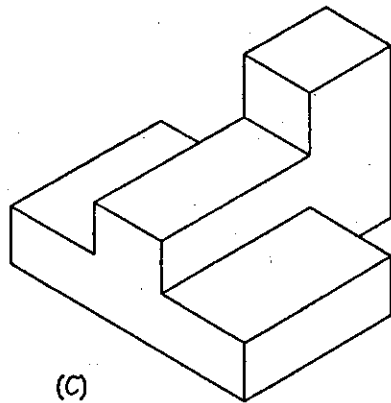
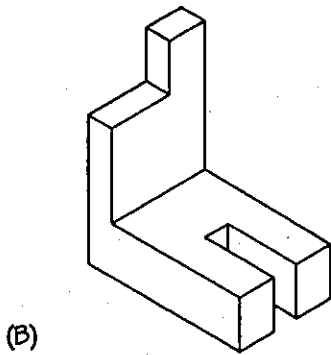
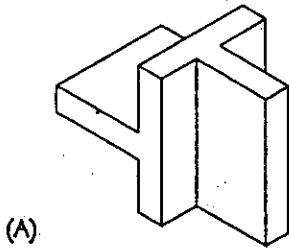

DRAWN BY _____ DATE _____